



**2009-25 Ram Classic
Mud Flap Set, 5/8" Offset, Rear
Mounting Diagram & Instructions
GB756834/GB756866**

IMPORTANT:

Manufacturer is not responsible for negligent use of vehicle with mud flaps installed, including over-tightening of screws and bolts causing damage to vehicle or mud flaps.



TOOLS REQUIRED-

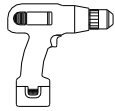

Electric or Chargeable
1/2" or 3/8" Drill



3/8" Socket Driver



1/4" Drill Bit

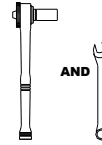

5/16 & 3/8" Open End
Wrench & Socket Wrench

SCREWS / FASTENERS / WASHERS / FLAPS - PARTS BAG # 755865

a) (1) Flap Assembly,
Front, DS



b) (1) Flap Assembly
Front, PS



c) (4) Screw, Machine
#10 x 1", SS
Part #012022



d) (8) Washer, Flat
0.203" x 1", SS
Part #018031



e) (4) Washer, Lock
#10, Helicoil, SS
Part #024001



f) (4) Hex Nut
#10, SS
Part #025003



INSTALLATION (For ease of installation it is suggested that the wheel be removed)

1. Before you install your Precision Mud Flap, see the diagram and parts list for all necessary parts. Cut the protective plastic and peel away from the stainless steel. Start on the driver's side.
2. Remove two (2) factory screws #5 & #6, on the wheel flare or wheel well, as shown in the diagram and reinstall the two (2) factory screws on holes #1 & #2, through the factory holes #5 & #6. Loosely secure at this point.
3. Square the flap with the tire, while putting pressure against the wheel flare, then tighten the two (2) factory screws on holes #1 & #2.

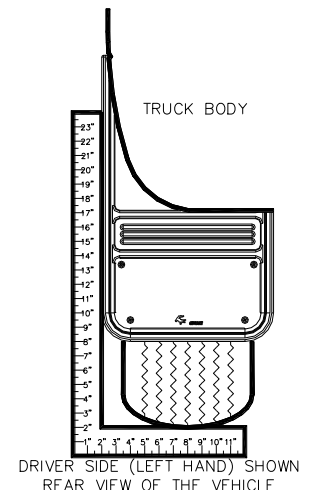

4. Drill 1/4" hole (2), from hole #3 to #4, through the factory plastic liner and secure these holes with two (2) machine screws #012022, four (4) flat washers #018031, two (2) lock washers #024001 and two (2) hex nuts #025003.
5. Repeat procedure for the passenger side.

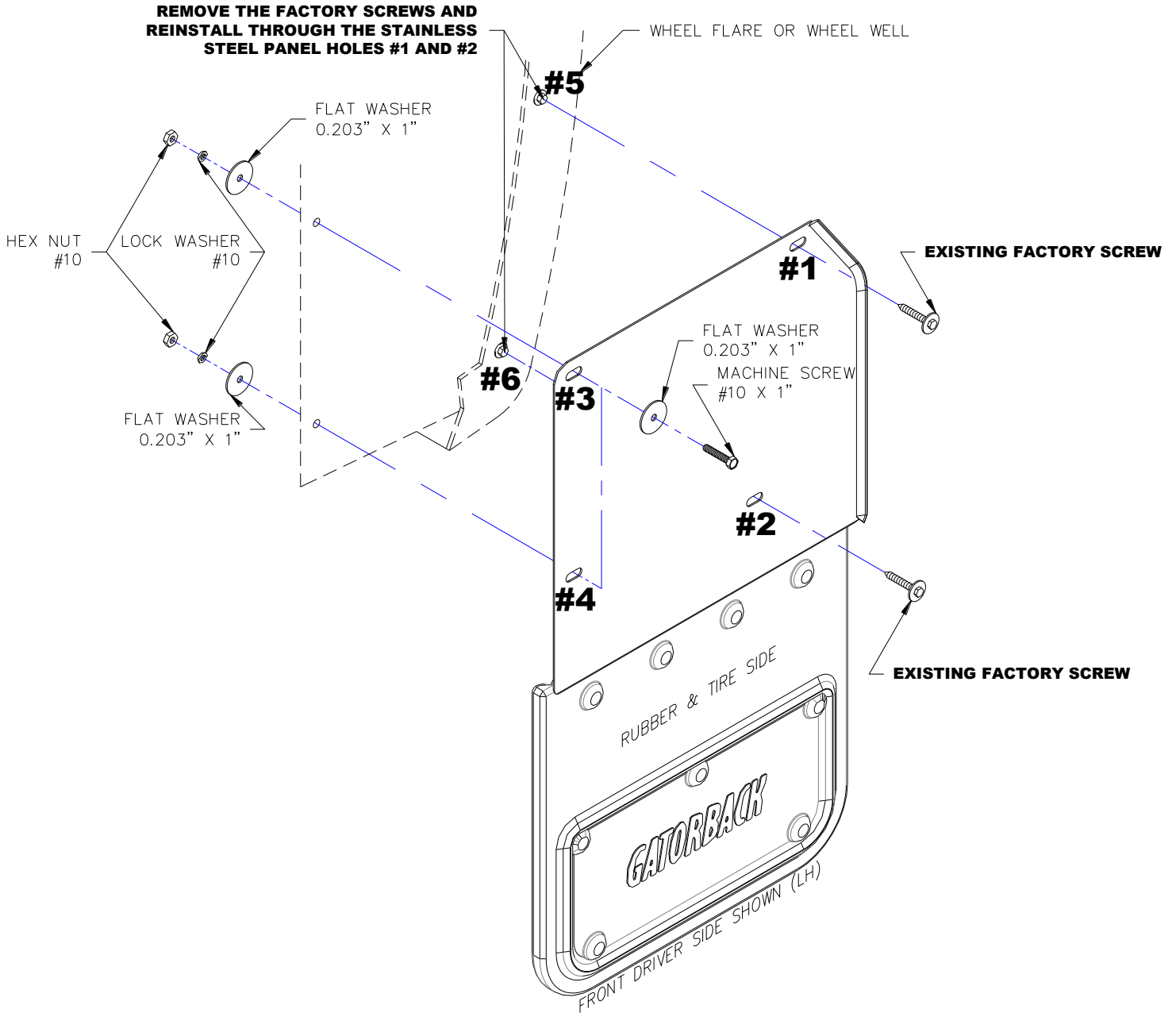

IMPORTANT:

Manufacturer is not responsible for negligent use of vehicle with Mud Flaps installed, or over tightening of screws and bolts causing damage to vehicle or mud flaps.